



# Technical Data

Specification & Capacities

## JVM800-R

# JVM800-R

## OVERALL DIMENSIONS JVM800-R

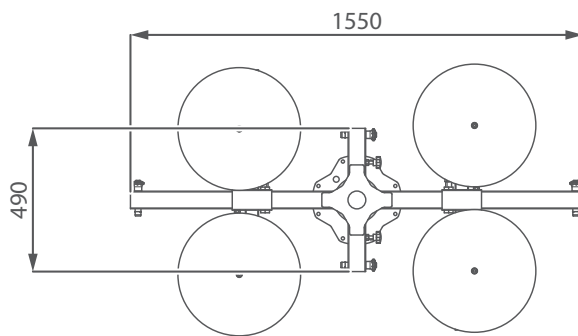
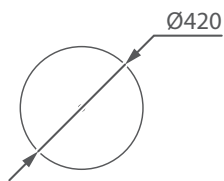
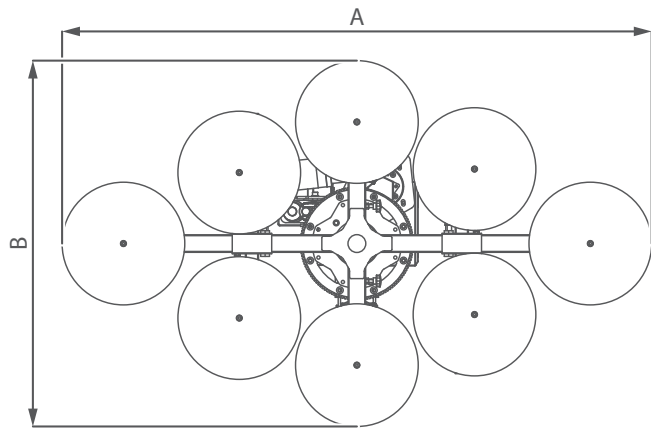
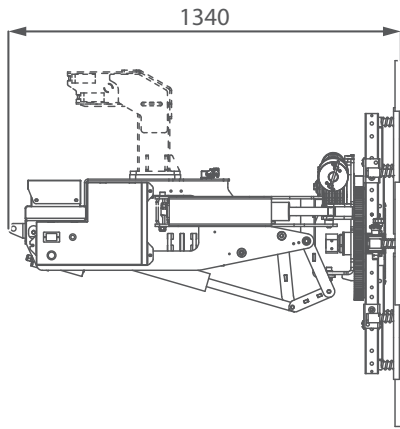

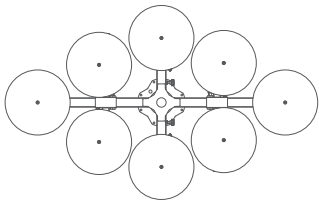
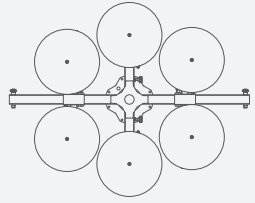
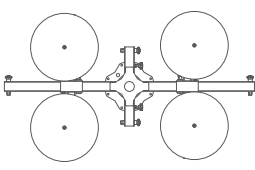
Configuration	Pads	Dim.	Minimum Pane Dimensions		Lifting capacity
			min [mm]	MAX [mm]	kg
	8	A	2020	2900	800
		B	1250	1250	
	6	A	1230	1800	600
		B	1250	1250	
	4	A	1230	1800	400
		B	920	1200	



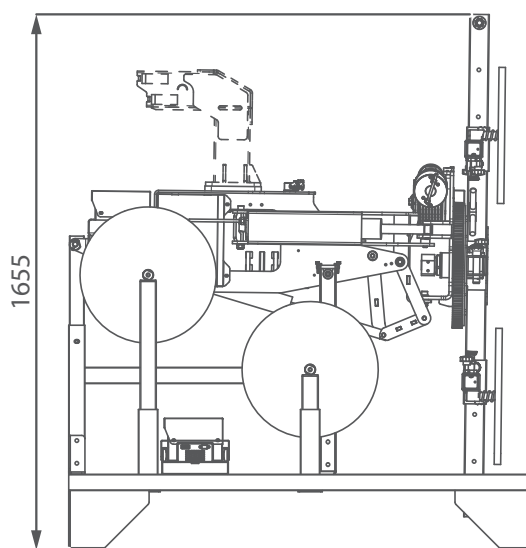
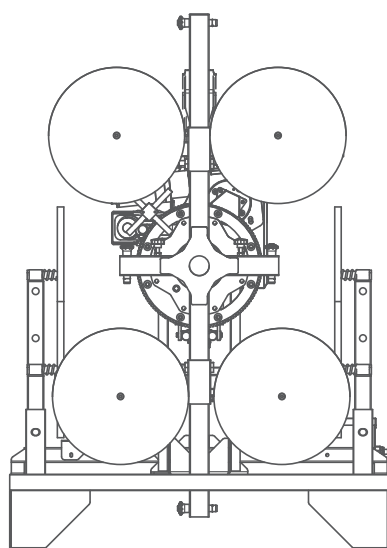
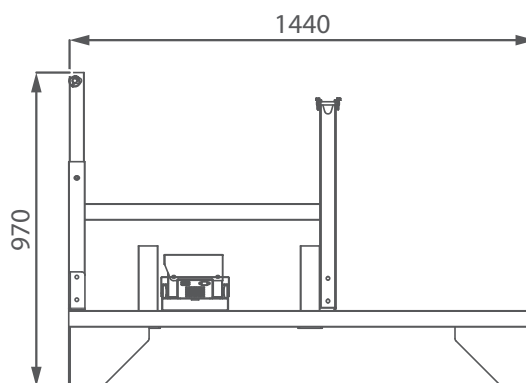
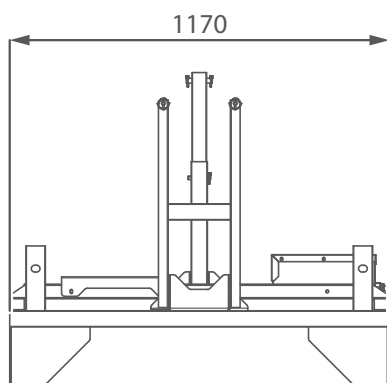

## OVERALL DIMENSIONS JVM800-R ON TRANSPORT TRAY



# JVM800-R

## OVERALL INFORMATION

WEIGHTS		Name/ version	kg	
		JVM800 (4 pads) with remote	JVM800-R	220
		Extra pad	Single position pad with support	5,5
		Four position pad with support	6,5	

MOVEMENTS	ELECTRIC			
		Lead Battery	24V 14,4 Ah	
		Tilt	+45° / -91°	
	Swing	+45° / -45°		
	Rotation	360°		
CAPACITY		Maximum Capacity	100 kg per pad	Max: 800 kg

## MOVEMENTS ROTATION

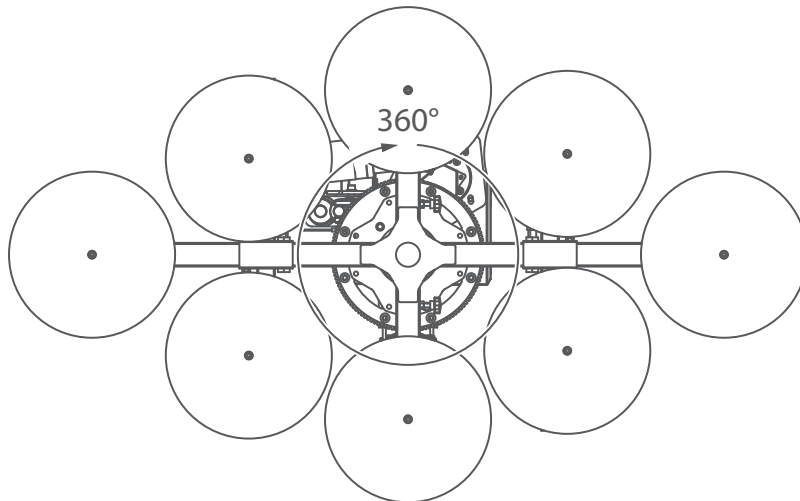

## MOVEMENTS



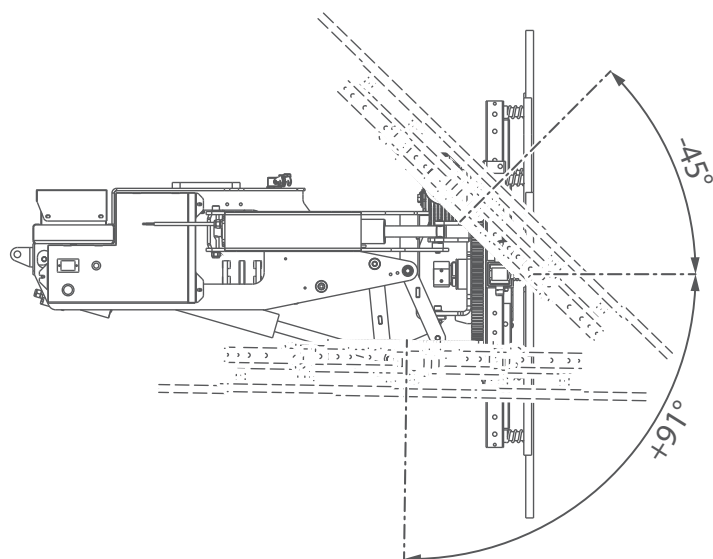



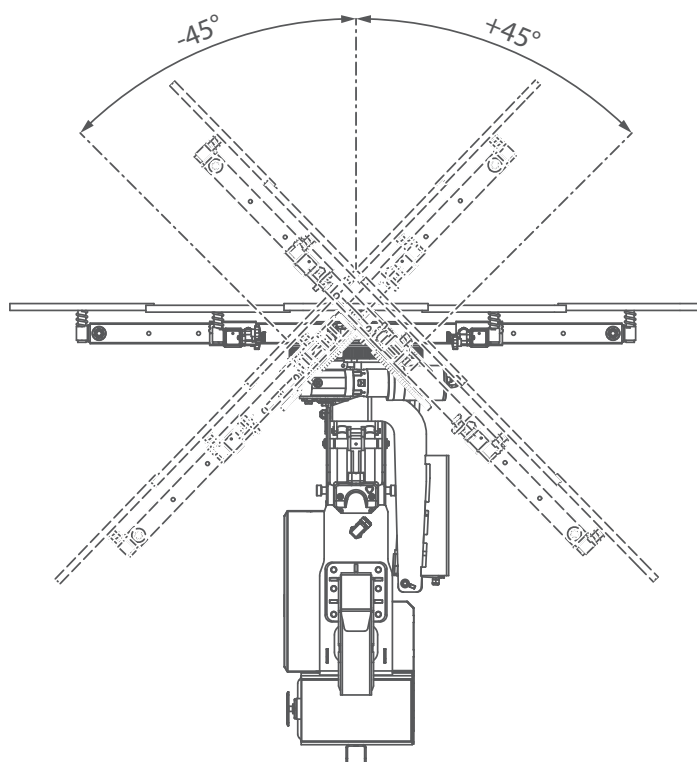













































### TILT



### SWING



## SYMBOLS

 Weight	 Engine	 Boom Angle	 Minipicker
 Counterweight	 Diesel Fuel	 Boom Length	 Back Wheel Loading Point
 Crane	 Petrol Fuel	 Boom Radius	 Front Wheel Loading Point
 Dimensions L x W x H	 Tank E F	 Jib on Board	 Working Radius
 Stabilization Area	 kW Power	 Without Jib on Board	 Stabilizing Bar
 Travel Speed	 Battery	 Jib Hook Radius	 EN Standard
 Gradeability	 Lithium Battery	 Jib Length and Angle	 Factory max. load
 MAX Outrigger Load	 Powerpack AUX	 Jib Length	 Building site max. load
 Track Loading	 Main Winch	 Jib Radius	 Maximum inclination of the machinery
 Outriggers Setup	 Hookblock	 Manipulator Length	 Hydraulic oil
 Ext Tracks Width W	 Slewing	 Manipulator Radius	 Winter Warm-up Kit
 Chart on Tracks	 Slewing Locked	 Number of vacuum pads	 Horizontal Boom Angle
 Slope	 Outriggers mats	 Grabber	 White Pads for Steel Tracks

### REMARKS REFERRING TO LOAD CHART

- The load charts are calculated according to EN 13000.
- For the calculation of the load charts at least a wind speed of 9m/s (33km/h) and regarding the load a sail area of 1m<sup>2</sup> per ton load and a wind resistance coefficient of 1.2 on the load have been taken into account. For lifting of loads with large sail areas and/or high wind resistance coefficients the maximum wind speed as stated in the load charts has to be reduced.
- Lifting capacities are given in kilograms.
- The weight of the hook blocks and hooks is part of the load and therefore it must be deducted from the lifting capacities.
- Working radii are measured from the slewing centre.
- The lifting capacities given for the telescopic boom apply if the folding jib is removed.
- Subject to modification of lifting capacities.